

Bracke M24.a

Two-row moulder

The Bracke M24.a is a light moulder for attachment on a mid-sized prime mover. This makes it suitable for smaller sites where high maneuverability is prioritized. The Bracke M24.a creates humus mounds with mineral soil cover, which means optimum planting spots. The method may vary, for example, to create patch scarification for sowing or in rocky soil. The Bracke M24.a provides good results on all mounding site types, but is particularly suitable where terrain conditions vary considerably.

Design

On the Bracke M24.a, the arms are articulated laterally to move aside for obstacles and create planting spots to one side. The lift arm hinges are a new design that provides a good lift height and the ability to lift the arms separately. The Bracke M24.a comes with both three- and four-pointed Mattock wheels (MW3 & MW4) to suit different market requirements. The hydraulics are load sensing.

Mattock wheel

The Mattock wheel's tooth plates make good planting spots with mineral soil coverage. The mounds can be compacted and soil impact is minimal. The design of the tooth plate allows its edge to maintain sharpness and results on the mounds are kept optimal throughout the life of the plate. Replacing the tooth plates is safe and simple.

Machine control

The Bracke M24.a has its own control system, which means it can easily be installed on forwarders, regardless of make. The display makes the system very user friendly and its functions easy to understand. The moulder is fitted with sensors that send information to the operator, e.g. prime mover speed and the rate of rotation of the mattock wheels. The control system has eight programmable operating profiles. The display is used to make settings in the control system and read information from the scarifier. The control system keeps track of the number of mounds of individual sites and in total, and the number of hours worked.

Scarification

The operator controls the Bracke M24.a from the cab. Any one of the eight preset operating profiles is selected at the press of a couple of buttons to adapt the unit's working method to achieve the best planting spots for the site concerned. The mattock wheels are hydraulically controlled and their rate of rotation is proportional to machine speed and adapted to the selected operating profile. The control system allows the operator to set up the Bracke M24.a to make mounds or scarify patches of varying length, depending on prevailing requirements.

Technical data

Prime mover	Forwarder/skidder 16 – 20 metric tons
Weight	3,000 kg
Mattock wheel	Choice of three- or four-pointed
Mattock wheel radius	725 mm
Hydraulic pressure	150 bar
Hydraulic flow	60 l/min
Electrical system	24V
Control system	PLC-based
Accessories	Seeder S35.a

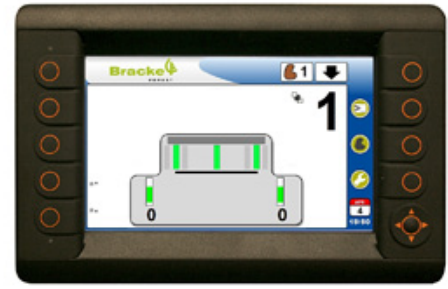

Display for settings and control of the moulder.

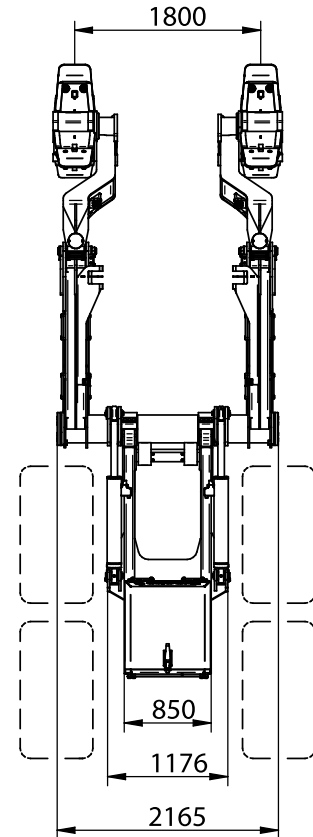
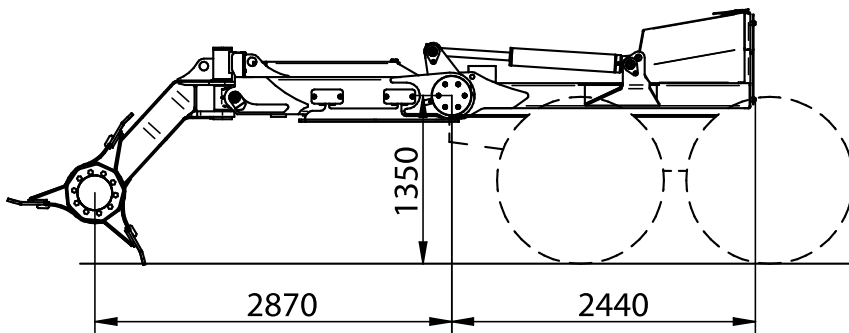

Scarification with the Bracke M24.a gives plants and seeds the best possible start for growth and survival whatever the terrain.



On a medium-sized forwarder, the Bracke M24.a provides very good scarification results on all mounding sites.

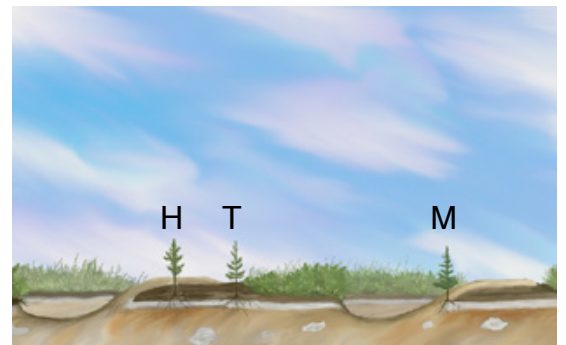

The Bracke M24.a creates planting spots with inverted humus (T), mineral soil mounds on inverted humus (H), and mineral soil mounds (M).

Bracke reserves the right to make changes. 2017-05-10



SILVANA IMPORT TRADING INC.
 4269 St. Catherine West, Suite 304, Montreal, Quebec Canada H3Z 1P7
 Toll Free: 1 888 939-3523 Phone: 1 514 939-3523 Fax: 1 514 939-3863
 info@silvanatrading.com www.silvanatrading.com
 www.brackeforest.ca